



HCS 20-2300

SCRAP SHEAR



BENEFITS

BOOM MOUNTED:
FOR 15 TO 20 TONS CARRIERS

STICK MOUNTED:
FOR 20 TO 30 TONS CARRIERS

STEEL MATERIAL
CUTTING AND RECYCLING

- **Standard 360° continuous rotation:** full maneuverability to reach optimal and accurate positioning on all jobsites.
- **Strong and fast:** powered by one oversized cylinder and a speed valve, to cut through the toughest materials in a very short time.
- **Adaptable tool:** adjustable guides on the left and right of the moving jaw for perfect alignment and optimal cutting.
- **Easy maintenance and low downtime:** HB steel blades exchangeable on jobsite, tip knife made from one part turnable two times and exchangeable on jobsite too.

SCRAP SHEAR
SHARP BLADE

HCS 20-2300

ATTACHMENT SPECS

WEIGHT - WITHOUT ADAPTER PLATE (KG - LB)	2,300	5,071
CLOSING FORCE (MIN - MAX, T)	117 - 550	

HYDRAULIC SPECS

OIL FLOW (MIN - MAX, L/MIN - GPM)	150 - 240	39.6 - 63.4
OPENING & CLOSING PRESSURE (MAX, BAR - PSI)	350	5,075
ROTATION FLOW (MAX, L/MIN - GPM)	45	11.9
ROTATION PRESSURE (MAX, BAR - PSI)	90	1,305

CARRIER SPECS

MOUNTED ON BOOM: WEIGHT (MIN - MAX, T)	15 - 20
MOUNTED ON STICK: WEIGHT (MIN - MAX, T)	20 - 30

DIMENSIONS (MM - IN)

A	2,905	114.3
B	1,130	44.4
C	540	21.2
D	576	22.6
E	730	28.7
F	325	12.7

CONSUMABLES

PRODUCT NUMBER

SPARE BLADES	contact us
BASIC MAINTENANCE KIT	contact us
ADVANCED MAINTENANCE KIT	contact us

CUTTING PERFORMANCES (MM - IN)

SOLID ROD	70	2.76
TUBE	220 x 8	8.66 x 0.31
IPN	400	15.75
HEA	300	11.81
HEB	220	8.66
PLATE	16	0.63
PROFILE L	220 x 15	8.66 x 0.59
RAIL VIGNOLA	NOT	NOT

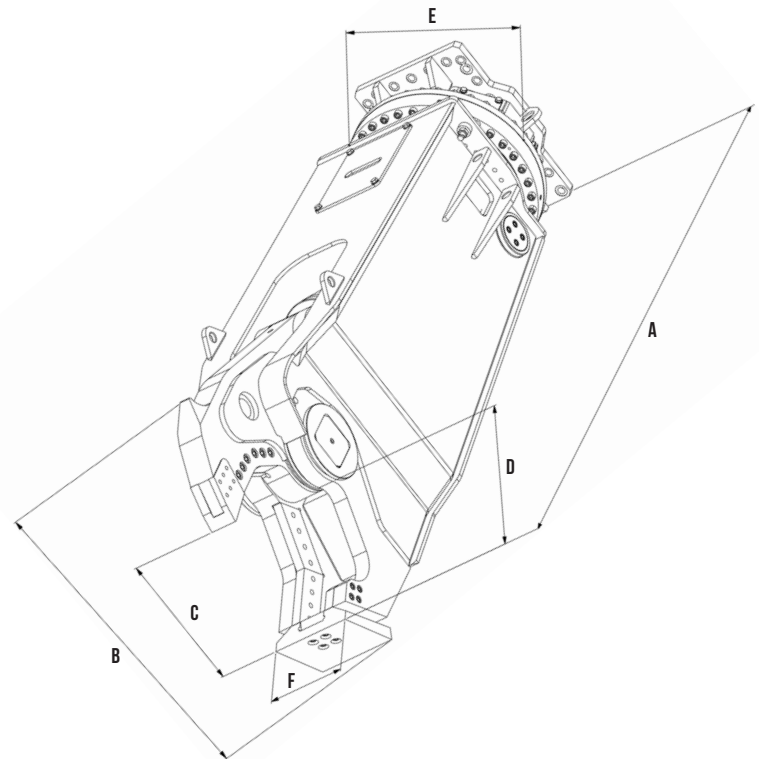

The content of this brochure constitutes non-binding information and may be changed at any time without notice. Montabert gives, and the brochure contains, no warranties whatsoever, express or implied. All the contents, including but not limited to text, images, graphics are all subject to copyright and all intellectual property protection. Their use or misuse is strictly prohibited. Montabert brand and logo used herein are the property of Montabert. Nothing contained on this document shall be construed as constituting any commitment by Montabert or as granting any license or right to use any intellectual property. ©2024 Montabert. All rights reserved.

montabert.com
montabertusa.com





HCS 30-3300

SCRAP SHEAR



BENEFITS

BOOM MOUNTED:
FOR 17 TO 25 TONS CARRIERS

STICK MOUNTED:
FOR 25 TO 40 TONS CARRIERS

STEEL MATERIAL
CUTTING AND RECYCLING

- **Standard 360° continuous rotation:** full maneuverability to reach optimal and accurate positioning on all jobsites.
- **Strong and fast:** powered by one oversized cylinder and a speed valve, to cut through the toughest materials in a very short time.
- **Adaptable tool:** adjustable guides on the left and right of the moving jaw for perfect alignment and optimal cutting.
- **Easy maintenance and low downtime:** HB steel blades exchangeable on jobsite, tip knife made from one part turnable two times and exchangeable on jobsite too.

SCRAP SHEAR
SHARP BLADE

HCS 30-3300

ATTACHMENT SPECS

WEIGHT - WITHOUT ADAPTER PLATE (KG - LB)	3,300	7,275
CLOSING FORCE (MIN - MAX, T)	147	617

HYDRAULIC SPECS

OIL FLOW (MIN - MAX, L/MIN - GPM)	200 - 330	52.8 - 87.1
OPENING & CLOSING PRESSURE (MAX, BAR - PSI)	320	4,640
ROTATION FLOW (MAX, L/MIN - GPM)	45	11.9
ROTATION PRESSURE (MAX, BAR - PSI)	90	1,305

CARRIER SPECS

MOUNTED ON BOOM: WEIGHT (MIN - MAX, T)	17 - 25
MOUNTED ON STICK: WEIGHT (MIN - MAX, T)	25 - 40

DIMENSIONS (MM - IN)

A	3,050	120
B	1,250	49.2
C	597	23.5
D	637	25
E	767	30.1
F	357	14

CONSUMABLES

PRODUCT NUMBER

SPARE BLADES	contact us
BASIC MAINTENANCE KIT	contact us
ADVANCED MAINTENANCE KIT	contact us

CUTTING PERFORMANCES (MM - IN)

SOLID ROD	85	3.35
TUBE	310 x 10	12.2 x 0.39
IPN	500	19.69
HEA	350	13.78
HEB	300	11.81
PLATE	20	0.79
PROFILE L	220 x 20	8.66 x 0.79
RAIL VIGNOLA	NOT	NOT

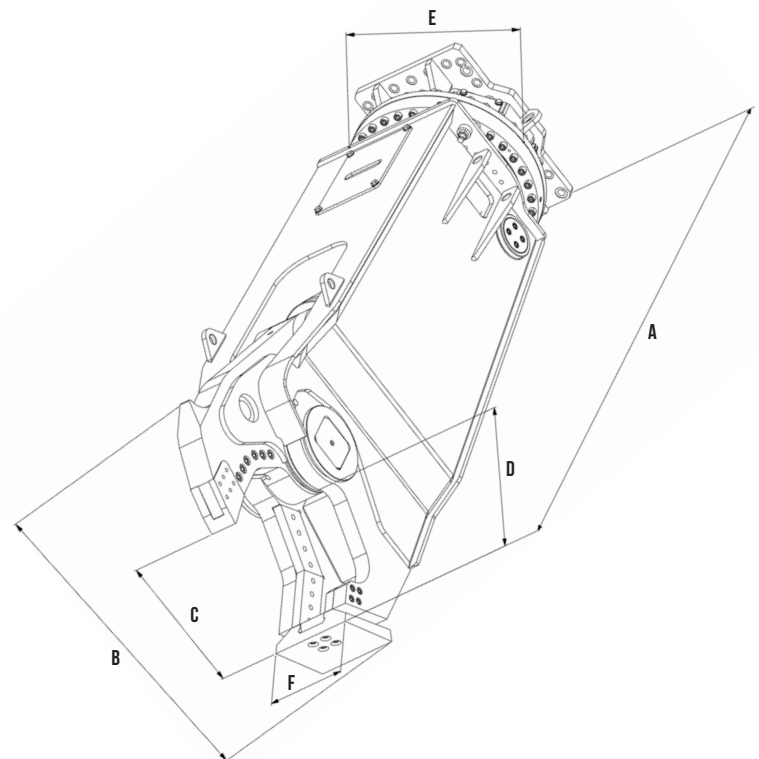

The content of this brochure constitutes non-binding information and may be changed at any time without notice. Montabert gives, and the brochure contains, no warranties whatsoever, express or implied. All the contents, including but not limited to text, images, graphics are all subject to copyright and all intellectual property protection. Their use or misuse is strictly prohibited. Montabert brand and logo used herein are the property of Montabert. Nothing contained on this document shall be construed as constituting any commitment by Montabert or as granting any license or right to use any intellectual property. ©2024 Montabert. All rights reserved.

montabert.com
montabertusa.com





HCS 40-4500

SCRAP SHEAR



BENEFITS

BOOM MOUNTED:
FOR 25 TO 35 TONS CARRIERS

STICK MOUNTED:
FOR 35 TO 50 TONS CARRIERS

STEEL MATERIAL
CUTTING AND RECYCLING

- **Standard 360° continuous rotation:** full maneuverability to reach optimal and accurate positioning on all jobsites.
- **Strong and fast:** powered by one oversized cylinder and a speed valve, to cut through the toughest materials in a very short time.
- **Adaptable tool:** adjustable guides on the left and right of the moving jaw for perfect alignment and optimal cutting.
- **Easy maintenance and low downtime:** HB steel blades exchangeable on jobsite, tip knife made from one part turnable two times and exchangeable on jobsite too.

SCRAP SHEAR
SHARP BLADE

HCS 40-4500

ATTACHMENT SPECS

WEIGHT - WITHOUT ADAPTER PLATE (KG - LB)	4,470	9,855
CLOSING FORCE (MIN - MAX, T)	224	924

HYDRAULIC SPECS

OIL FLOW (MIN - MAX, L/MIN - GPM)	270 - 370	71.3 - 97.7
OPENING & CLOSING PRESSURE (MAX, BAR - PSI)	350	5,075
ROTATION FLOW (MAX, L/MIN - GPM)	45	11.9
ROTATION PRESSURE (MAX, BAR - PSI)	110	1,595

CARRIER SPECS

MOUNTED ON BOOM: WEIGHT (MIN - MAX, T)	25 - 35
MOUNTED ON STICK: WEIGHT (MIN - MAX, T)	35 - 50

DIMENSIONS (MM - IN)

A	3,447	135.7
B	1,450	57
C	714	28.1
D	720	28.3
E	865	34
F	405	15.9

CONSUMABLES

PRODUCT NUMBER

SPARE BLADES	contact us
BASIC MAINTENANCE KIT	contact us
ADVANCED MAINTENANCE KIT	contact us

CUTTING PERFORMANCES (MM - IN)

SOLID ROD	105	4.13
TUBE	430 x 12	16.93 x 0.47
IPN	630	24.80
HEA	440	17.32
HEB	340	13.39
PLATE	25	0.98
PROFILE L	220 x 25	8.66 x 0.98
RAIL VIGNOLA	NOT	NOT

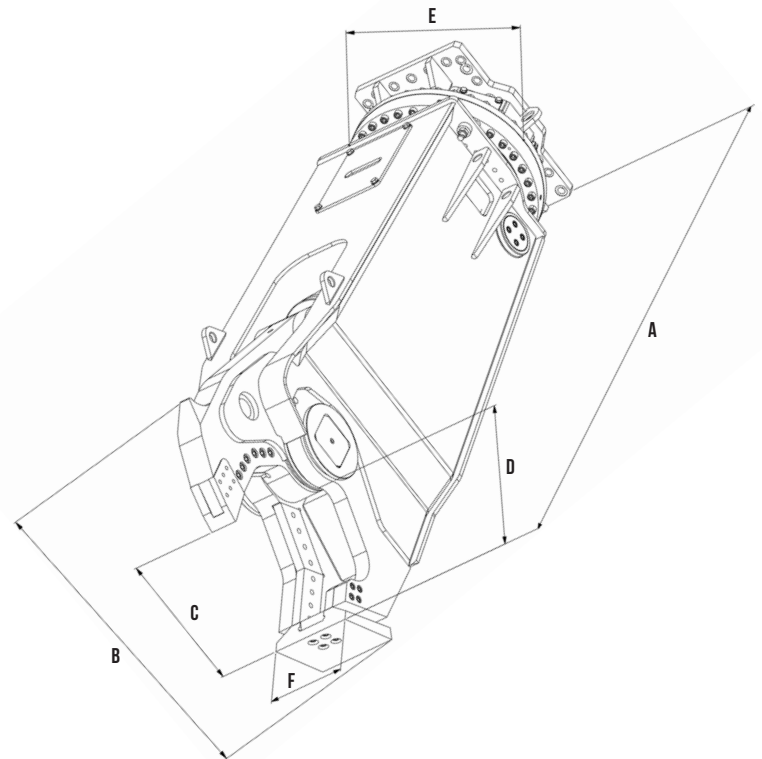

The content of this brochure constitutes non-binding information and may be changed at any time without notice. Montabert gives, and the brochure contains, no warranties whatsoever, express or implied. All the contents, including but not limited to text, images, graphics are all subject to copyright and all intellectual property protection. Their use or misuse is strictly prohibited. Montabert brand and logo used herein are the property of Montabert. Nothing contained on this document shall be construed as constituting any commitment by Montabert or as granting any license or right to use any intellectual property. ©2024 Montabert. All rights reserved.

montabert.com
montabertusa.com





HCS 50-5500

SCRAP SHEAR



BENEFITS

BOOM MOUNTED:
FOR 30 TO 50 TONS CARRIERS

STICK MOUNTED:
FOR 45 TO 65 TONS CARRIERS

STEEL MATERIAL
CUTTING AND RECYCLING

- **Standard 360° continuous rotation:** full maneuverability to reach optimal and accurate positioning on all jobsites.
- **Strong and fast:** powered by one oversized cylinder and a speed valve, to cut through the toughest materials in a very short time.
- **Adaptable tool:** adjustable guides on the left and right of the moving jaw for perfect alignment and optimal cutting.
- **Easy maintenance and low downtime:** HB steel blades exchangeable on jobsite, tip knife made from one part turnable two times and exchangeable on jobsite too.

SCRAP SHEAR
SHARP BLADE

HCS 50-5500

ATTACHMENT SPECS

WEIGHT - WITHOUT ADAPTER PLATE (KG - LB)	5,500	12,125
CLOSING FORCE (MIN - MAX, T)	272	1,111

HYDRAULIC SPECS

OIL FLOW (MIN - MAX, L/MIN - GPM)	330 - 450	87.1 - 118.8
OPENING & CLOSING PRESSURE (MAX, BAR - PSI)	350	5,075
ROTATION FLOW (MAX, L/MIN - GPM)	45	11.9
ROTATION PRESSURE (MAX, BAR - PSI)	110	1,595

CARRIER SPECS

MOUNTED ON BOOM: WEIGHT (MIN - MAX, T)	30 - 50
MOUNTED ON STICK: WEIGHT (MIN - MAX, T)	45 - 65

DIMENSIONS (MM - IN)

A	3,700	145.6
B	1,570	61.8
C	770	30.3
D	771	30.3
E	948	37.3
F	447	17.5

CONSUMABLES

PRODUCT NUMBER

SPARE BLADES	contact us
BASIC MAINTENANCE KIT	contact us
ADVANCED MAINTENANCE KIT	contact us

CUTTING PERFORMANCES (MM - IN)

SOLID ROD	115	4.53
TUBE	520 x 15	20.47 x 0.59
IPN	720	28.35
HEA	520	20.47
HEB	380	14.96
PLATE	25	0.98
PROFILE L	270 x 25	10.63 x 0.98
RAIL VIGNOLA	NOT	NOT

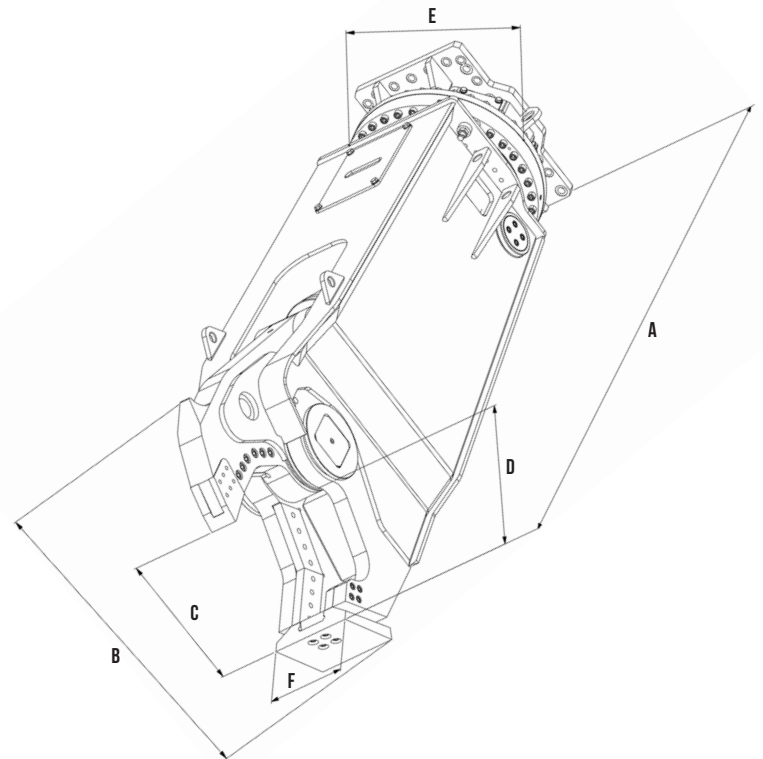

The content of this brochure constitutes non-binding information and may be changed at any time without notice. Montabert gives, and the brochure contains, no warranties whatsoever, express or implied. All the contents, including but not limited to text, images, graphics are all subject to copyright and all intellectual property protection. Their use or misuse is strictly prohibited. Montabert brand and logo used herein are the property of Montabert. Nothing contained on this document shall be construed as constituting any commitment by Montabert or as granting any license or right to use any intellectual property. ©2024 Montabert. All rights reserved.

montabert.com
montabertusa.com

