

**STANDARD SPECIFICATIONS**

	JGXR-10	JGXR-15	JGXR-20	JGXR-30	JGXR-40
<b>Excavator Class - mt</b>	8 - 12	13 - 16	18 - 23	23 - 30	34 - 40
<b>Weight w/ bracket lbs (kg)</b>	2,050 (930)	3,748 (1,700)	5,512 (2,500)	7,275 (3,300)	9,260 (4,200)
<b>Weight w/o bracket lbs (kg)</b>	1,828 (829)	3,417 (1,550)	4,850 (2,200)	6,173 (2,800)	7,937 (3,600)
<b>Frequency - bpm</b>	1,400 - 1,500	1,300 - 1,400	1,300 - 1,400	1,200 - 1,300	1,100 - 1,200
<b>Hydraulic Working Pressure psi (Mpa)</b>	2,175 - 2,610 (15 - 18)	2,320 - 2,755 (16 - 19)	2,610 - 2,900 (18 - 20)	3,190 - 3,480 (22 - 24)	3,190 - 3,480 (22 - 24)
<b>Hydraulic Return Pressure psi (Mpa)</b>	90 (0.6)	90 (0.6)	90 (0.6)	90 (0.6)	90 (0.6)
<b>Case Drain Max Pressure psi (Mpa)</b>	NA	60 (0.4)	60 (0.4)	60 (0.4)	60 (0.4)
<b>Hydraulic Oil Flow gpm (L/min)</b>	16 (60)	32 (120)	42 (160)	48 (180)	53 (200)
<b>Dimension L inch (mm)</b>	66 (1,680)	87 (2,200)	95 (2,400)	110 (2,800)	122 (3,100)
<b>Dimension W inch (mm)</b>	18 (450)	26 (660)	31 (780)	34 (850)	35 (900)
<b>Dimension H inch (mm)</b>	35 (900)	51 (1,300)	69 (1,750)	63 (1,600)	72 (1,840)

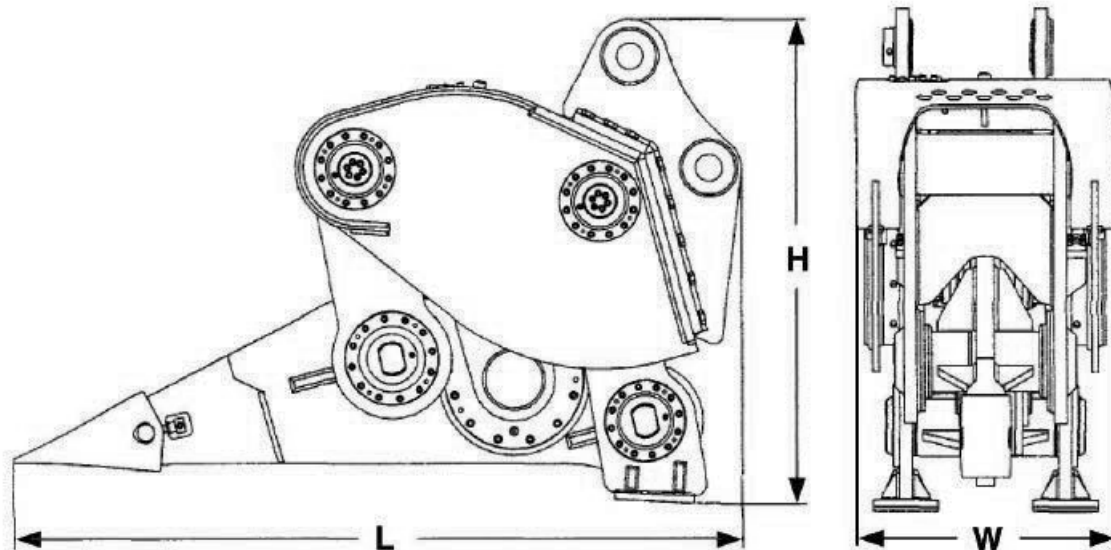

# STANDARD SPECIFICATIONS

	<b>JGXR-50</b>	<b>JGXR-60</b>	<b>JGXR-80</b>	<b>JGXR-120</b>
<b>Excavator Class - mt</b>	40 - 50	60 - 80	80 - 90	100 - 120
<b>Weight w/ bracket lbs (kg)</b>	12,346 (5,600)	15,432 (7,000)	23,148 (10,500)	28,660 (13,000)
<b>Weight w/o bracket lbs (kg)</b>	11,023 (5,000)	12,566 (5,700)	19,180 (8,700)	24,250 (11,000)
<b>Frequency - bpm</b>	900 - 1,000	900 - 1,000	900 - 1,000	900 - 1,000
<b>Hydraulic Working Pressure psi (Mpa)</b>	3,770 - 4,060 ( 26 - 28)	3,770 - 4,060 (26 - 28)	4,350 - 4,640 (30 -32 )	3,190 - 3,480 (22 - 24)
<b>Hydraulic Return Pressure psi (Mpa)</b>	90 (0.6)	90 (0.6)	90 (0.6)	90 (0.6)
<b>Case Drain Max Pressure psi (Mpa)</b>	60 (0.4)	60 (0.4)	60 (0.4)	60 (0.4)
<b>Hydraulic Oil Flow gpm (L/min)</b>	66 (250)	74 (280)	100 (380)	114 (430)
<b>Dimension L inch (mm)</b>	126 (3,200)	136 (3,450)	150 (3,800)	158 (4,000)
<b>Dimension W inch (mm)</b>	35 (900)	43 (1,100)	52 (1,320)	52 (1,320)
<b>Dimension H inch (mm)</b>	75 (1,900)	85 (2,170)	90 (2,300)	111 (2,820)