



XCENTRIC RIPPER





HIGH-CAPACITY PRODUCTION REDUCED COSTS

The Xcentric Ripper is an excavator attachment developed for high-performance rock excavation and demolition work. At production rates 2 to 5 times greater than a hydraulic breaker, the Xcentric Ripper allows you to finish jobs quickly and efficiently, saving you time and money.

The Xcentric Ripper is made of the highest quality components for long life. Built completely of wear-resistant steel, it can handle the toughest work site conditions. The Xcentric Ripper is virtually maintenance free with 1,000 hour lube intervals, is extremely quiet, can be used under water without any risk of damage and can be adapted to work on countless job sites.





GREAT PERFORMANCE DIVERSE ENVIRONMENTS

The internal components of the Xcentric Ripper can't be damaged by water, dust or dirt, which means it can work without restriction in the most severe conditions such as tunnels, quarries, harbors and trenching. In under water applications, the Ripper can be used without making complicated, expensive preparations, which saves on high maintenance and repair costs typically associated with these conditions.

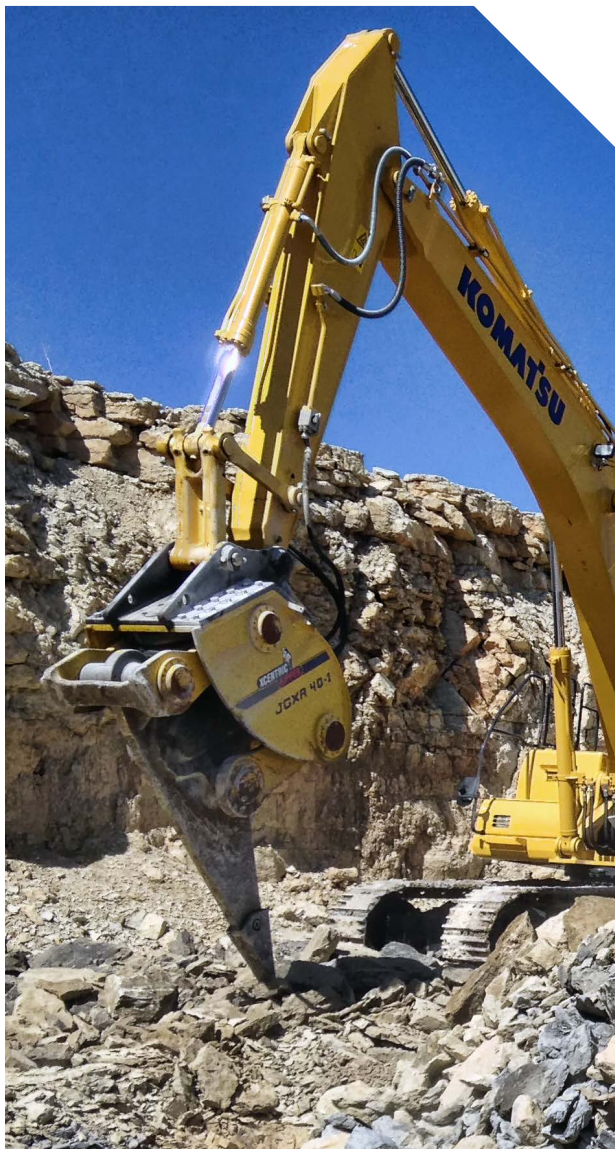

PERFORMANCE

OUTPERFORMS HYDRAULIC BREAKERS IN 85% OF JOB APPLICATIONS

- ▷ 2 to 5 times better production than breakers
- ▷ Minimum noise levels
- ▷ Minimum maintenance
- ▷ No daily lubrication required
- ▷ Minimum wear parts consumption
- ▷ Long life components and materials
- ▷ Less fuel consumption per produced yd³/ton
- ▷ Less emission per produced yd³/ton
- ▷ Economical alternative to "Drilling and Blasting"
- ▷ Marine/underwater operation
- ▷ Easy operation
- ▷ Increased operator comfort



9 MODELS TO CHOOSE FROM

The Xcentric Ripper is available in an extensive range of models for excavators from 8 to 120 metric tons. This gives you the flexibility to match the right excavator/ripper combination to your application.



Model Type	Excavator Class - mt	Weight - lbs (kg)		Frequency bpm	Hydraulic Working Pressure	
		w/ bracket	w/o bracket		psi	Mpa
JGXR-10	8 - 12	2,050 [930]	1,828 [829]	1,400 - 1,500	2,175 - 2,610	15 - 18
JGXR-15	13 - 16	3,748 [1,700]	3,417 [1,550]	1,300 - 1,400	2,320 - 2,755	16 - 19
JGXR-20	18 - 23	5,512 [2,500]	4,850 [2,200]	1,300 - 1,400	2,610 - 2,900	18 - 20
JGXR-30	23 - 30	7,275 [3,300]	6,173 [2,800]	1,200 - 1,300	3,190 - 3,480	22 - 24
JGXR-40	34 - 40	9,260 [4,200]	7,937 [3,600]	1,100 - 1,200	3,190 - 3,480	22 - 24
JGXR-50	40 - 50	12,346 [5,600]	11,023 [5,000]	900 - 1,000	3,770 - 4,060	26 - 28
JGXR-60	60 - 80	15,432 [7,000]	12,566 [5,700]	900 - 1,000	3,770 - 4,060	26 - 28
JGXR-80	80 - 90	23,148 [10,500]	19,180 [8,700]	900 - 1,000	4,350 - 4,640	30 - 32
JGXR-120	100 - 120	28,660 [13,000]	24,250 [11,000]	900 - 1,000	3,190 - 3,480	22 - 24

XCENTRIC RIPPER



Hydraulic Return Pressure		Case Drain Max Pressure		Max Hydraulic Oil Flow		Dimension - inch (mm)		
psi	Mpa	psi	Mpa	gpm	L/min	L	W	H
90	0.6	N/A	N/A	16	60	66 [1,680]	18 [450]	35 [900]
90	0.6	60	0.4	32	120	87 [2,200]	26 [660]	51 [1,300]
90	0.6	60	0.4	42	160	95 [2,400]	31 [780]	69 [1,750]
90	0.6	60	0.4	48	180	110 [2,800]	34 [850]	63 [1,600]
90	0.6	60	0.4	53	200	122 [3,100]	35 [900]	72 [1,840]
90	0.6	60	0.4	66	250	126 [3,200]	35 [900]	75 [1,900]
90	0.6	60	0.4	74	280	136 [3,450]	43 [1,100]	85 [2,170]
90	0.6	60	0.4	100	380	150 [3,800]	52 [1,320]	90 [2,300]
90	0.6	60	0.4	114	430	158 [4,000]	52 [1,320]	111 [2,820]

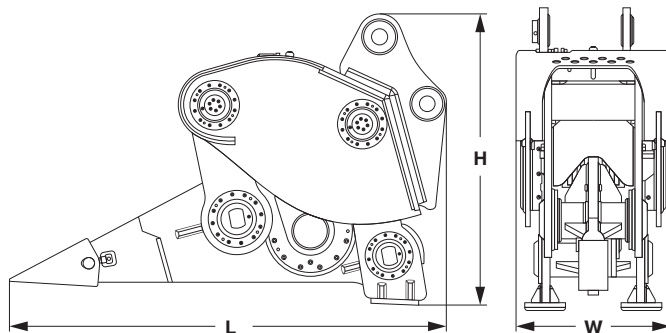

COMPARISON TO HYDRAULIC BREAKERS

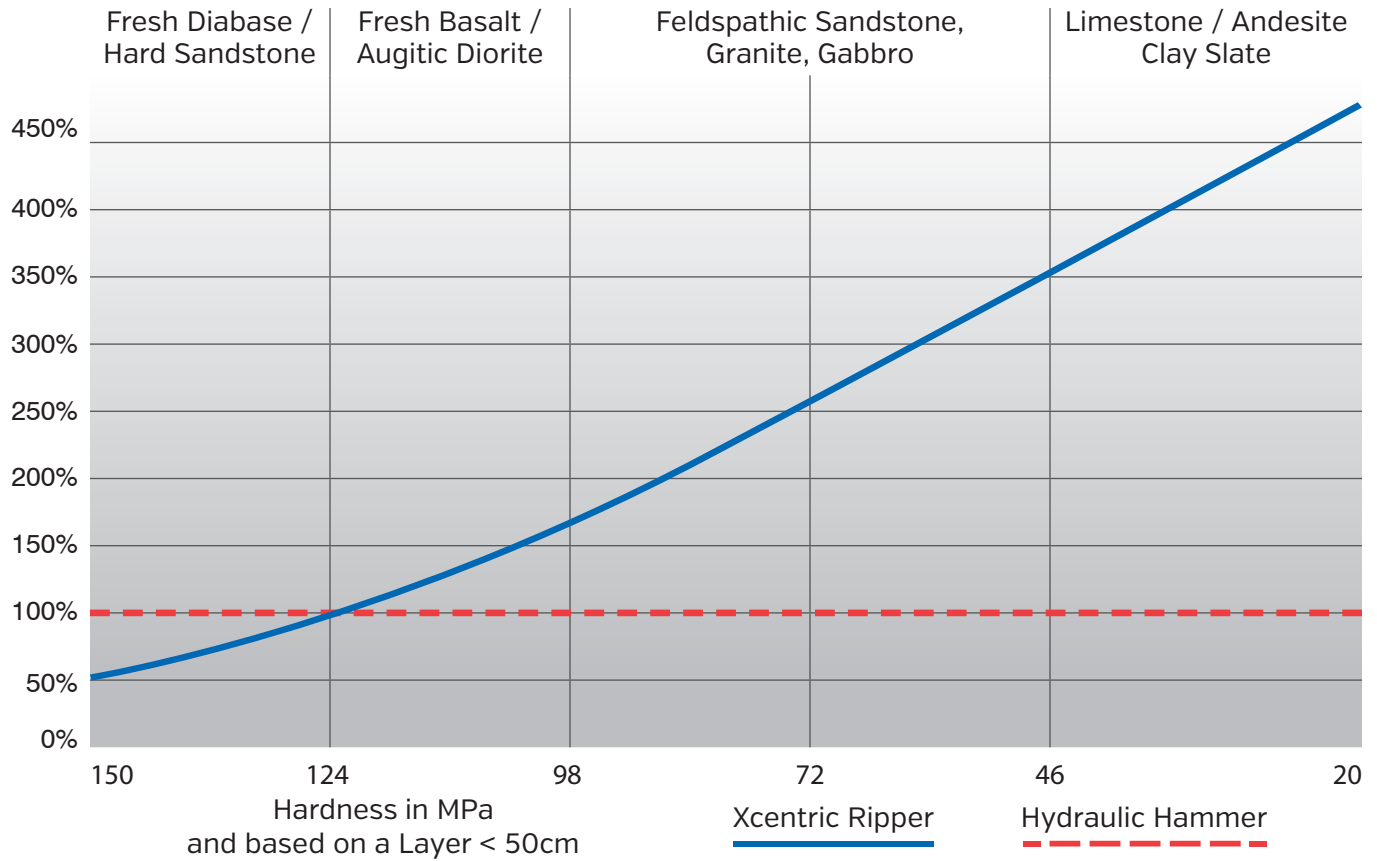

FEASIBILITY IN ROCK

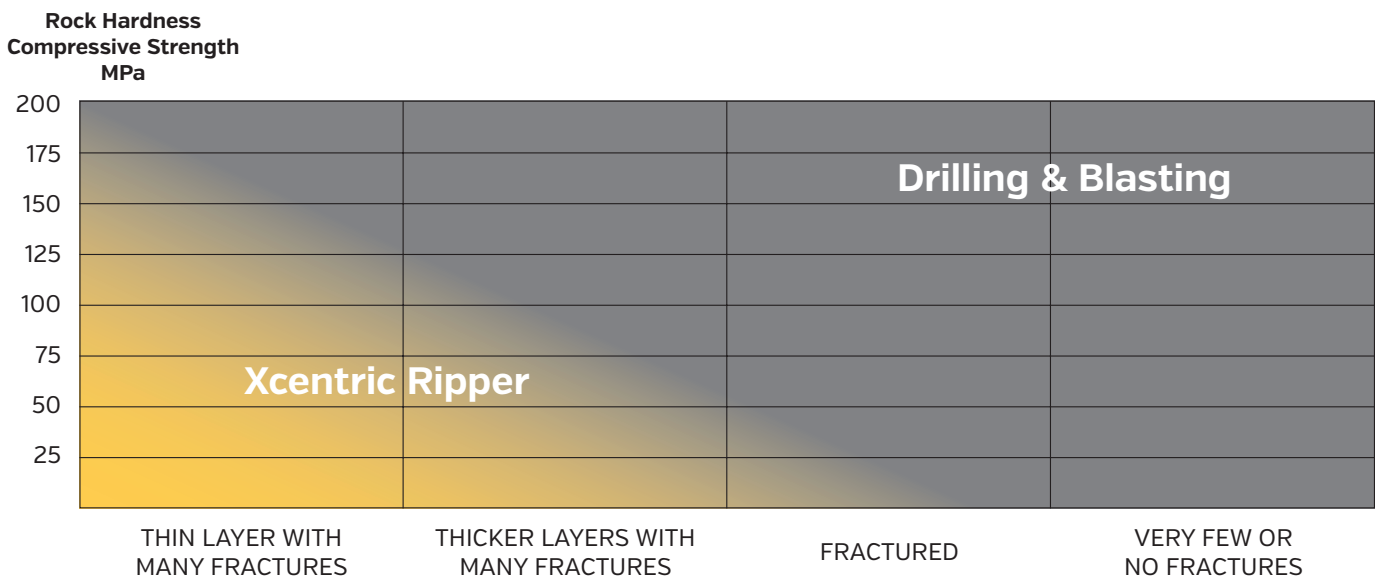

The Xcentric Ripper can handle a wide variety of rock and hardnesses. Depending on hardness, certain compositions of layered or fractured rock can be broken easier than rock with few fractures.



EXTREME STRENGTH **LONG LIFE COMPONENTS**

In quarries with a limited volume of production or where drilling and blasting is no longer permitted for environmental or safety reasons, the Xcentric Ripper can be the best way to get reasonable production costs.

