



HYDRAULIC ROCK BREAKER

SC50



COMPACT FRAME
WITH HEAVY POWER

DESIGNED FOR
7 TO 14 TONNES CARRIERS

LIGHTER, LEANER,
MORE POWERFUL

TIE RODS FREE BREAKER

BENEFITS

- Hydraulic accumulator: no more regular nitrogen controls and recharges on jobsite.
- Automatic lubrication: cartridge grease pump mounted on breaker.
- Made in France: superior quality steel and manufacturing excellence.
- Blank firing protection: increased wear parts lifespan.

COMPACT FRAME
WITH HEAVY POWER

WEIGHT & DIMENSIONS

WEIGHT (KG/LB)

BREAKER	385	849
+ MOUNTED TOOL	429	946
+ MOUNTED ADAPTER PLATE (MAX)	546	1,204

DIMENSIONS (MM/IN)

A	1,870	73.6
B	1,790	70.4
C	1,130	40.48
D	425	16.7
E	270	10.6
F	310	12.2
G	40	1.57

OPERATING INFORMATION

CARRIER WEIGHT RANGE (MIN-MAX, MT)	7-14	
OIL FLOW (MIN-MAX, L/MIN, GPM)	75-125	19.8-33
MAXIMUM OPERATING PRESSURE (BAR/PSI)	130	1,885
MAXIMUM BACK PRESSURE (BAR/PSI)	20	290
INPUT POWER (KW)	27.1	
STRIKING FREQUENCY (MIN-MAX, BPM)	600-1,137	
NOISE LEVEL /10M (DBA)	93	
SOUNDPROOFING	standard	
PRESSURIZATION	preinstalled	

OPTIONS

CPN

AUTOMATIC LUBRICATION KIT	86767787
PRESSURIZATION KIT	86654696
ADAPTER PLATE	upon request
SPECIAL PAINTING	upon request

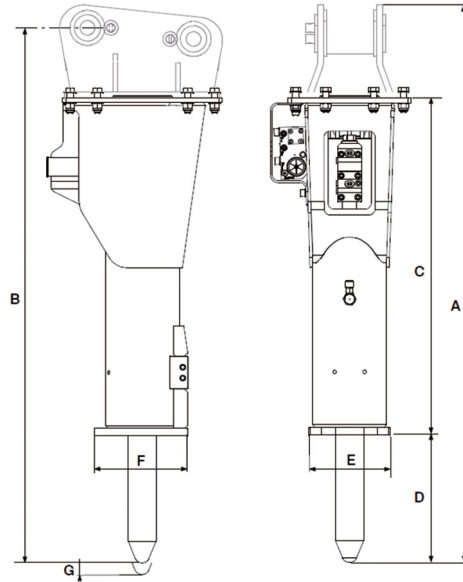

TOOLS

DIAMETER (MM/IN)	94/3.7	94/3.7	94/3.7
LENGTH (MM/IN)	850/33.4	850/33.4	850/33.4
WEIGHT (KG/LB)	44/97	44/97	44/97
CPN	86565652	86565645	86655081

CONSUMABLES

CPN

GREASE CARTRIDGES (X48, HAND PUMP)	86799152
GREASE CARTRIDGES (X48, AUTOMATIC LUBRICATION)	86784758

MAINTENANCE KITS

CPN

LEVEL 1	86685609
LEVEL 3	86690567



The content of this brochure constitutes non-binding information and may be changed at any time without notice. Montabert gives, and the brochure contains, no warranties whatsoever, express or implied. All the contents, including but not limited to text, images, graphics are all subject to copyright and all intellectual property protection. Their use or misuse is strictly prohibited. Montabert, KMC or Komatsu trademarks used herein are the property of their respective companies. Nothing contained on this document shall be construed as constituting any commitment by Montabert or as granting any license or right to use any intellectual property. ©2019 Montabert. All rights reserved.





HYDRAULIC ROCK BREAKER

501NG



COMPACT FRAME
WITH HEAVY POWER

DESIGNED FOR
9 TO 16 TONNES CARRIERS

LIGHTER, LEANER,
MORE POWERFUL

TIE RODS FREE BREAKER

BENEFITS

- Hydraulic accumulator: no more regular nitrogen controls and recharges on jobsite.
- Automatic lubrication: cartridge grease pump mounted on breaker, or tank mounted on excavator.
- Made in France: superior quality steel and manufacturing excellence.
- Blank firing protection: increased wear parts lifespan.

HYDRAULIC ROCK BREAKER

COMPACT FRAME WITH HEAVY POWER

WEIGHT & DIMENSIONS

WEIGHT (KG/LB)

BREAKER	600	1,322
+ MOUNTED TOOL	665	1,465
+ MOUNTED ADAPTER PLATE (MAX)	843	1,858

DIMENSIONS (MM/IN)

A	1,241	48.85
B	567	22.32
C	280	11.02
D	430	16.92
E	51	2
F	8	0.314

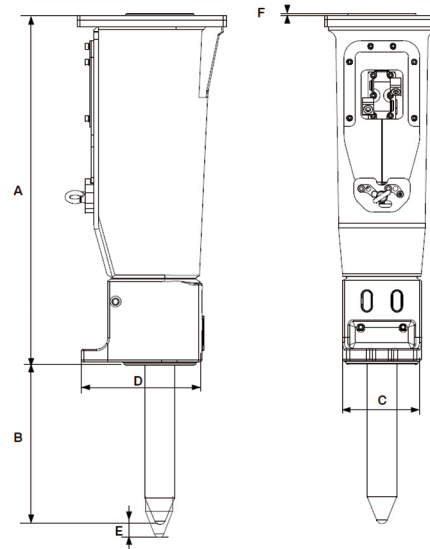

OPERATING INFORMATION

CARRIER WEIGHT RANGE (MIN-MAX, MT)	9-16	
OIL FLOW (MIN-MAX, L/MIN, GPM)	80-140	21.1-37
MAXIMUM OPERATING PRESSURE (BAR/PSI)	140	2,031
MAXIMUM BACK PRESSURE (BAR/PSI)	15	218
INPUT POWER (KW)	32.6	
STRIKING FREQUENCY (MIN-MAX, BPM)	420-870	
NOISE LEVEL /10M (DBA)	96	
SOUNDPROOFING	standard	
PRESSURIZATION	preinstalled	

CONSUMABLES

CONSUMABLES	CPN
GREASE CARTRIDGES (X48, HAND PUMP)	86799152
GREASE CARTRIDGES (X48, AUTOMATIC LUBRICATION)	86784758

OPTIONS

OPTIONS	CPN
AUTOMATIC LUBRICATION KIT	86768124
PRESSURIZATION KIT	86777695
ADAPTER PLATE	upon request
SPECIAL PAINTING	upon request

MAINTENANCE KITS

MAINTENANCE KITS	CPN
LEVEL 1	86778180
LEVEL 2	86778198

TOOLS

TOOLS	CPN	CPN	CPN	CPN
DIAMETER (MM/IN)	106/4.17	106/4.17	106/4.17	106/4.17
LENGTH (MM/IN)	1,005/39.56	1,005/39.56	1,005/39.56	1,005/39.56
WEIGHT (KG/LB)	62/137	63/139	66/146	62/137
CPN	86722451	86722154	86722444	86622469



The content of this brochure constitutes non-binding information and may be changed at any time without notice. Montabert gives, and the brochure contains, no warranties whatsoever, express or implied. All the contents, including but not limited to text, images, graphics are all subject to copyright and all intellectual property protection. Their use or misuse is strictly prohibited. Montabert, KMC or Komatsu trademarks used herein are the property of their respective companies. Nothing contained on this document shall be construed as constituting any commitment by Montabert or as granting any license or right to use any intellectual property. ©2019 Montabert. All rights reserved.

montabert.com





HYDRAULIC ROCK BREAKER

M900



COMPACT FRAME
WITH HEAVY POWER

DESIGNED FOR
15 TO 25 TONNES CARRIERS

PROVEN RELIABILITY

USER FRIENDLY

BENEFITS

- Hydraulic accumulator: no more regular nitrogen controls and recharges on jobsite.
- Automatic lubrication: cartridge grease pump mounted on breaker, or tank mounted on excavator.
- Made in France: superior quality steel and manufacturing excellence.
- Blank firing protection: increased wear parts lifespan.

HYDRAULIC ROCK BREAKER

COMPACT FRAME WITH HEAVY POWER

M900

WEIGHT & DIMENSIONS

WEIGHT (KG/LB)

BREAKER	853	1,881
+ MOUNTED TOOL	956	2,108
+ MOUNTED ADAPTER PLATE (MAX)	1,211	2,670

DIMENSIONS (MM/IN)

A	1,645	64.76
B	475	18.7
C	461.5	18.17
D	284	11.18
E	52	2.05

OPERATING INFORMATION

CARRIER WEIGHT RANGE (MIN-MAX, MT)	15-25
OIL FLOW (MIN-MAX, L/MIN, GPM)	100-150 26.4-40
MAXIMUM OPERATING PRESSURE (BAR/PSI)	125 1,813
MAXIMUM BACK PRESSURE (BAR/PSI)	10 145
INPUT POWER (KW)	39.6
STRIKING FREQUENCY (MIN-MAX, BPM)	400-800
NOISE LEVEL /10M (DBA)	95
SOUNDPROOFING	standard
PRESSURIZATION	preinstalled

OPTIONS

CPN

AUTOMATIC LUBRICATION KIT LEFT HP (CARTRIDGES)	86767720
AUTOMATIC LUBRICATION KIT RIGHT HP (CARTRIDGES)	86779014
CARRIER MOUNTED AUTOMATIC LUBRICATION KIT	86417243
PRESSURIZATION KIT	86411154
ADAPTER PLATE	upon request
SPECIAL PAINTING	upon request

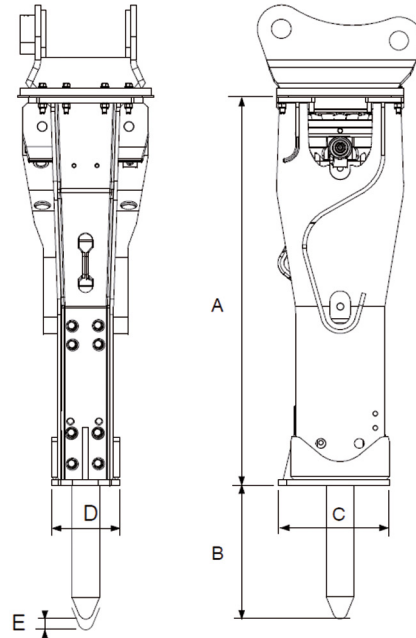

CONSUMABLES

CPN

GREASE CARTRIDGES (X48, HAND PUMP)	86799152
GREASE CARTRIDGES (X48, AUTOMATIC LUBRICATION)	86784758

MAINTENANCE KITS

CPN

LEVEL 1	86603990
LEVEL 2	86604022

TOOLS

DIAMETER (MM/IN)	118	118	118	118	118
LENGTH (MM/IN)	1,000/39.4	1,300/51.2	1,000/39.4	1,300/51.2	1,000/39.4
WEIGHT (KG/LB)	77/170	102/225	76/168	103/227	80.6/177.6
CPN	86730579	86421948	86730561	86643681	86797651



The content of this brochure constitutes non-binding information and may be changed at any time without notice. Montabert gives, and the brochure contains, no warranties whatsoever, express or implied. All the contents, including but not limited to text, images, graphics are all subject to copyright and all intellectual property protection. Their use or misuse is strictly prohibited. Montabert, KMC or Komatsu trademarks used herein are the property of their respective companies. Nothing contained on this document shall be construed as constituting any commitment by Montabert or as granting any license or right to use any intellectual property. ©2019 Montabert. All rights reserved.

montabert.com





HYDRAULIC ROCK BREAKER

M900MS



COMPACT FRAME
WITH HEAVY POWER

DESIGNED FOR
15 TO 25 TONNES CARRIERS

PROVEN RELIABILITY

USER FRIENDLY

EXTRA SOUNDPROOFING

BENEFITS

- Hydraulic accumulator: no more regular nitrogen controls and recharges on jobsite.
- Automatic lubrication: cartridge grease pump mounted on breaker, or tank mounted on excavator.
- Made in France: superior quality steel and manufacturing excellence.
- Blank firing protection: increased wear parts lifespan.

HYDRAULIC ROCK BREAKER

COMPACT FRAME WITH HEAVY POWER

WEIGHT & DIMENSIONS

WEIGHT (KG/LB)

BREAKER	927	2,043
+ MOUNTED TOOL	1,030	2,270
+ MOUNTED ADAPTER PLATE (MAX)	1,285	2,833

DIMENSIONS (MM/IN)

A	1,686	66.37
B	434	17.09
C	461.5	18.17
D	289	11.38
E	52	2.05

OPERATING INFORMATION

CARRIER WEIGHT RANGE (MIN-MAX, MT)	15-25
OIL FLOW (MIN-MAX, L/MIN, GPM)	100-150 26.4-40
MAXIMUM OPERATING PRESSURE (BAR/PSI)	125 1,813
MAXIMUM BACK PRESSURE (BAR/PSI)	10 145
INPUT POWER (KW)	39.6
STRIKING FREQUENCY (MIN-MAX, BPM)	400-800
NOISE LEVEL /10M (DBA)	92
SOUNDPROOFING	standard
PRESSURIZATION	preinstalled

OPTIONS

CPN

AUTOMATIC LUBRICATION KIT LEFT HP (CARTRIDGES)	86767720
AUTOMATIC LUBRICATION KIT RIGHT HP (CARTRIDGES)	86779014
CARRIER MOUNTED AUTOMATIC LUBRICATION KIT	86417243
PRESSURIZATION KIT	86411154
ADAPTER PLATE	upon request
SPECIAL PAINTING	upon request

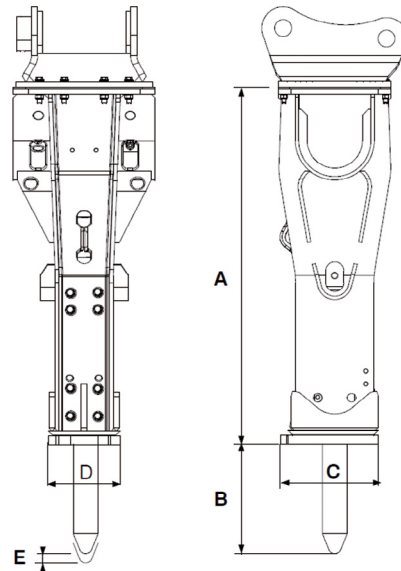

CONSUMABLES

CPN

GREASE CARTRIDGES (X48, HAND PUMP)	86799152
GREASE CARTRIDGES (X48, AUTOMATIC LUBRICATION)	86784758
ABL2 GREASE BUCKET (24 KG)	86772969
ABLF GREASE BUCKET (24 KG)	86772977

MAINTENANCE KITS

CPN

LEVEL 1	86603990
LEVEL 2	86604022

TOOLS

DIAMETER (MM/IN)	118	118	118	118	118
LENGTH (MM/IN)	1,000/39.4	1,300/51.2	1,000/39.4	1,300/51.2	1,000/39.4
WEIGHT (KG/LB)	77/170	102/225	76/168	103/227	80.6/177.6
CPN	86730579	86421948	86730561	86643681	86797651



The content of this brochure constitutes non-binding information and may be changed at any time without notice. Montabert gives, and the brochure contains, no warranties whatsoever, express or implied. All the contents, including but not limited to text, images, graphics are all subject to copyright and all intellectual property protection. Their use or misuse is strictly prohibited. Montabert, KMC or Komatsu trademarks used herein are the property of their respective companies. Nothing contained on this document shall be construed as constituting any commitment by Montabert or as granting any license or right to use any intellectual property. ©2019 Montabert. All rights reserved.

montabert.com

